



Machinery



Over 35 Years and Counting

Nugent Engineering was founded in 1985 by Sean Nugent. Coming from an agricultural background, he designed and manufactured agricultural products, selling cattle handling equipment to local farmers and distributors.

A distribution network throughout Ireland was established over the next 5 years and the product mix developed to agricultural implements, driven through a demand for strong, robust machinery.

Sons Shane and Damien Nugent joined their father in the early 90's, when the first Livestock trailer was created.

The family business continued to grow, offering a wide range of commercial trailer products to export markets.

In 2017, Nugent opened a purpose built, state of the art trailer assembly facility. This has allowed the company to move from a static build to three fully fledged production lines. This was followed in 2019 by a modern 3,700 sq ft office development and a 10,000 sq ft plate shop extensions with brand new laser cutting facilities.



The Nugent family take pride in their agricultural roots, maintaining the location at the original site, with a strong connection to the local community.

A diverse workforce has developed through expansion sustaining an affiliation with local colleges to create a variety of career opportunities locally as well as welcoming a growing number of skilled multi-national team members.

Bale Handling	Euro Bale Spike	4
	Universal Bale Spike	4
	Bale Grab	5
	Hydraulic Bale Stacker	5
	Single Bale Lifter (Heavy Duty)	6
	Twin Bale Lifter	6
	Duo Bale Attach	7
	Round Bale Cutter	8
	Round Bale Feeder	9
Round Bale Feeder Guide Kit	9	
Brackets	Brackets	10
	Brackets	11
Machinery	Link Boxes	12
	Grass Topper	13
	Mini Muck Spreader	14
	Galvanised Yard Scraper	15
Cattle Handling	Universal Hoof Tech	16
	Prime 3000	18
	Pro 2000	20
	Pure 1000	22
Extras	Dairy Head Locking Gate	24
	Beef Head Locking Gate	24
	Universal Head Locking Gate	25
	Manual Head Locking Gate	25
	Hoof Trimming Kit	26
	Hoof Trimmer Rear Guide Gates	26
	Rear Crush Gates	27
	Forklift Points	28
	Ratchet Rump Bar	28
	Head Scoop	29
	3-point Linkage H Frame	29
	Digital Weigh System	30
Nugent Trailers	30	

Euro Bale Spike

- Heavy duty tines
- Ideal for transporting silage, haylage & straw
- Euro brackets are standard
- Other brackets available on request

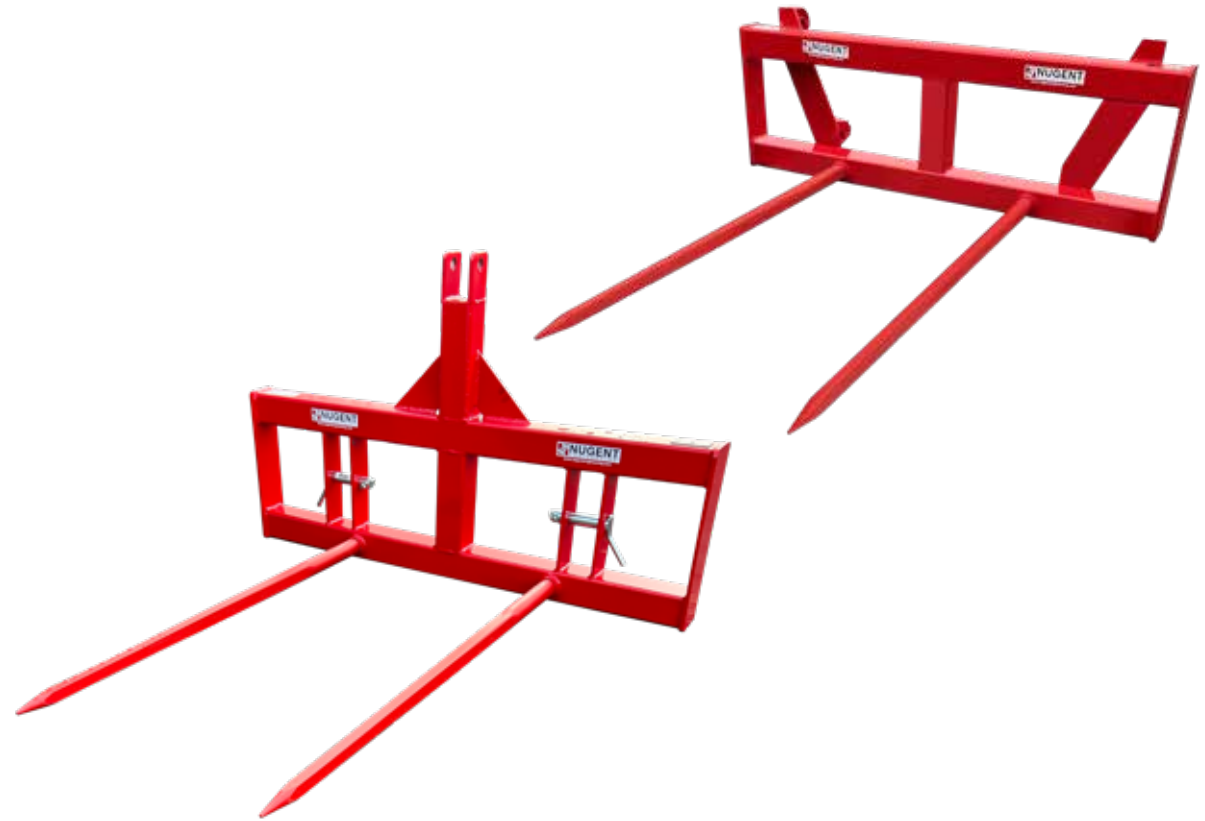

Universal Bale Spike

- Efficient for longer journeys
- 3-point linkage as standard
- Heavy duty tines
- Ideal for transporting silage, haylage & straw

MODEL	PRODUCT CODE	HEIGHT (mm)	WIDTH (mm)	WEIGHT (kg)
Euro Bale Spike	BHEBSA	456	1,190	55
Universal Bale Spike	BHUBSA	785	1,265	61

The above specifications are approximate as our products are under continuous development, so there may be changes and adjustments.

Bale Grab

- For fast, efficient movement of bales
- Two hydraulic arms that squeeze in and open out
- Ability to fix one arm for stacking in those awkward places
- Perfect for stacking bales and loading bales into high feeders
- Fitted with anti-creep valve to prevent loss of pressure
- Available with a range of bolt on brackets
- Minimal damage to bale
- No nip points

Hydraulic Bale Stacker

- Rotating rollers ensure no film damage when carrying wrapped bales
- Sleeves are removable to act as a Bale Spike
- Available with a range of bolt on brackets
- Fitted with spring steel tines so it can carry two bales of straw
- Removable heavy duty sleeves with domed endcap to reduce bale damage



MODEL	PRODUCT CODE	HEIGHT (mm)	WIDTH (mm)	WEIGHT (kg)
Bale Grab	BHBGSA	600	1,300	230
Bale Grab with Euro Brackets	BHBGEA	650	1,300	240
Hydraulic Bale Stacker	BHHSSA	850	1,210	150
Hydraulic Bale Stacker with Euro Brackets	BHHSEA	900	1,210	160

The above specifications are approximate as our products are under continuous development, so there may be changes and adjustments.

Single Bale Lifter (Heavy Duty)

- 3-point linkage as standard
- Hydraulic trip available on request
- Robust box section A-Frame, for a stronger 3-point linkage system
- Heavy duty legs with machined domed end to reduce risk of damaging bale
- Spring-loaded trip mechanism for standing the bale on its end
- Rounded bull bar to act as a bale stop



Twin Bale Lifter

- Strength and reliability to carry two of the largest bales
- Constructed from heavy duty box section
- Hydraulic tipping mechanism
- Reduces time and effort for the farmer
- 3-point linkage as standard
- Easy access grease points
- Rounded bull bar to act as a bale stop
- Heavy duty legs with machined domed end to reduce risk of damaging bale



MODEL	PRODUCT CODE	HEIGHT (mm)	WIDTH (mm)	WEIGHT (kg)
Single Bale Lifter (Heavy Duty)	BHSBLA	870	1,190	110
Twin Bale Lifter	BHTBLA	870	1,900	280

The above specifications are approximate as our products are under continuous development, so there may be changes and adjustments.

Duo Bale Attach

- The Duo Bale Attach allows independent movement of each Bale Lifter for fast and simple collection
- The Duo Bale Lifter is made up of the Duo Bale Attach and two existing Nugent Bale Lifters
- The single Bale Lifters can be detached and used independently in winter
- Lifts the first bale of the ground to protect it whilst lifting the second bale
- Tips in the traditional tipping format, allowing farmers to not only lift two bales at a time but to stand them up on their end independently



* Note: Bale Lifters not included

MODEL	PRODUCT CODE	HEIGHT (mm)	WIDTH (mm)	WEIGHT (kg)
Duo Bale Attach	BHDUOA	880	2,510	190

The above specifications are approximate as our products are under continuous development, so there may be changes and adjustments.

Round Bale Cutter

- The Round Bale Cutter comes with six heavy duty tines
- The wrap catch latches onto bale wrap to dispose of separately
- Specially designed to catch all types of wrap and net
- Serrated front blades splits bales with ease the full way through
- Reliable and durable design due to hardened cutting edge
- Extra tine locations available



MODEL	PRODUCT CODE	HEIGHT (mm)	WIDTH (mm)	WEIGHT (kg)
Round Bale Cutter	BHBCSA	766	1,810	373

The above specifications are approximate as our products are under continuous development, so there may be changes and adjustments.

Round Bale Feeder

- High quality motor protected from exposure
- Adjustable feed rate
- Quick attach automated locking system
- Rear guard for extra protection & prevention of overspill
- Two sided feeding
- Heavy duty floor bars
- Heavy duty tines (can be used as a Bale Spike)
- Wide flared, easy guide cones
- Couplings for secure connection



Round Bale Feeder Guide Kit

- Ideal for oval or flattened bales
- Ensures large lumps are released
- Sides can be sold separately or together

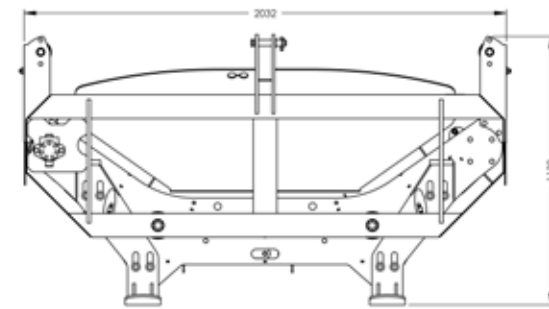
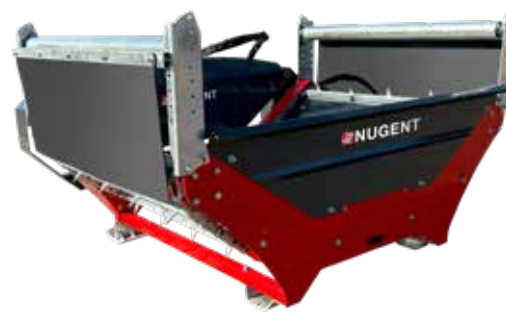

MODEL	PRODUCT CODE	HEIGHT (mm)	WIDTH (mm)	WEIGHT (kg)
Round Bale Feeder	BHRBFA	1,260	2,020	595
Round Bale Feeder Guide Kit	BHEFGA	1,130	2,032	650

The above specifications are approximate as our products are under continuous development, so there may be changes and adjustments.

Bolt-on Brackets

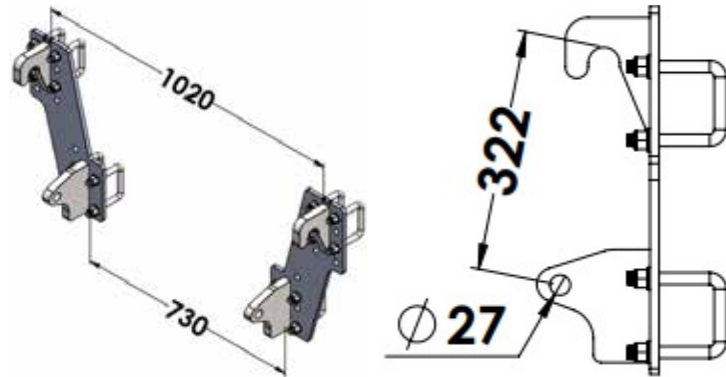

LBEURA - Loader Brackets Bolt on Euro (Stacker & Grab)
LBEURB - Loader Brackets Bolt on Euro (Bale Cutter)

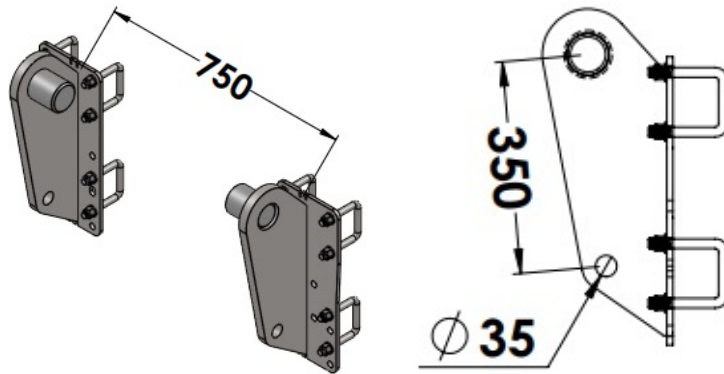

* **LBMTUA** - Loader Brackets Bolt on Manitou

* Suitable for Stacker, Grab & Bale Cutter

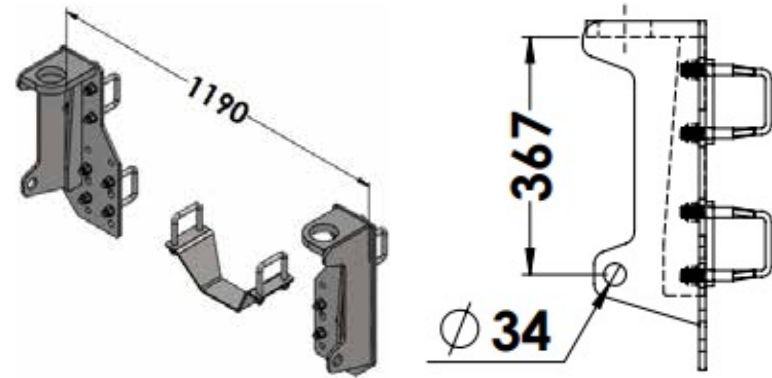

* **LBMTBA** - Loader Brackets Bolt on Matbro

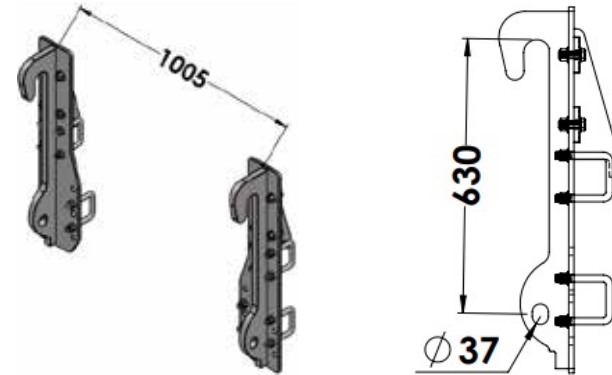

* **LBQFTA** - Loader Brackets Bolt on JCB Q-Fit

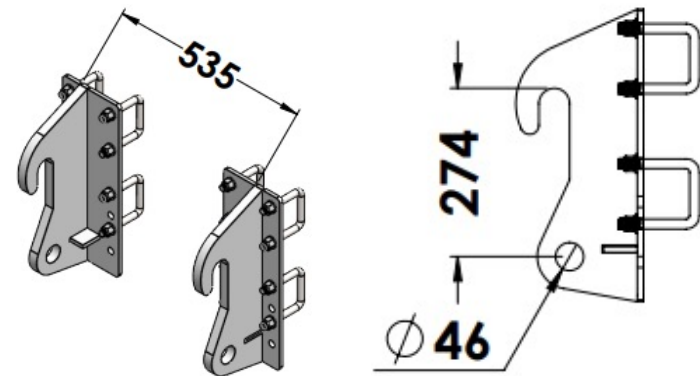

* **LBCPTA** - Loader Brackets Bolt on JCB Compact

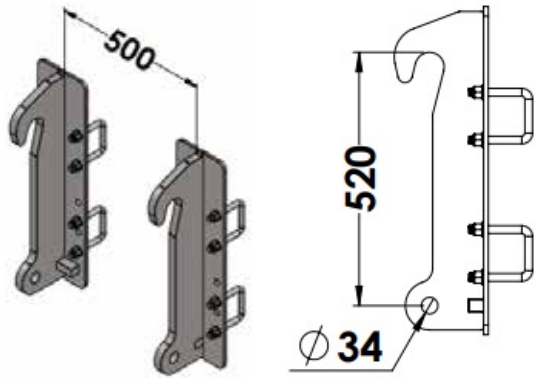

* **LBTCBA** - Loader Brackets Bolt on JCB Tool Carrier

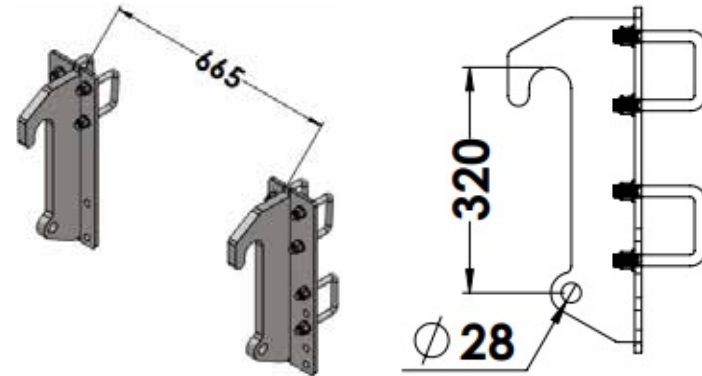

* **LBTRIA** - Loader Brackets Bolt on Trima

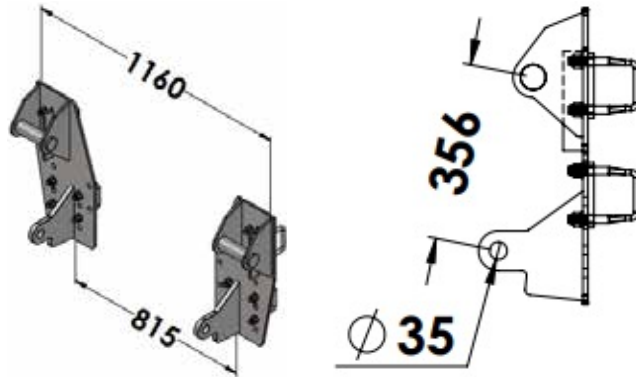

LBCLTA - Loader Brackets Bolt on Chilton

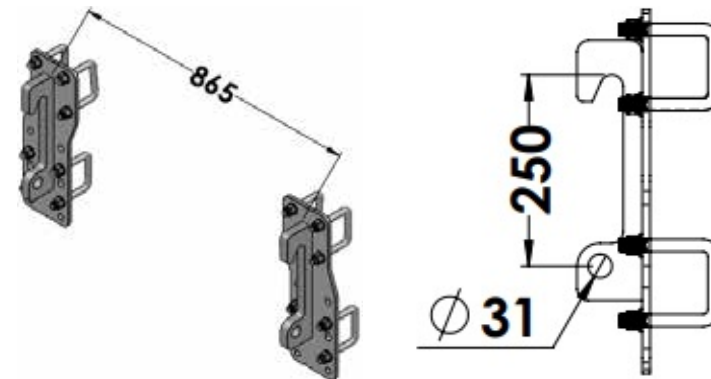

* **LBQUIA** - Loader Brackets Bolt on Quickie

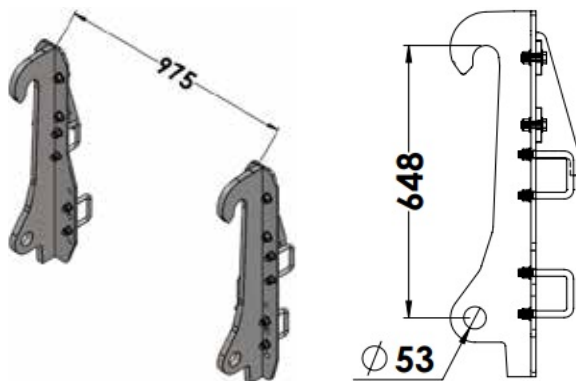

* **LBVOLA** - Loader Brackets Bolt on Volvo

Other bolt-on brackets available upon request

Link Boxes

Power Link Box

- Full range of sizes available 6' to 7'
- Durable construction designed to last
- Suitable for 2 wheel or 4 wheel drive tractors
- Universal 3-point linkage for easy operation
- Heavy duty A-frame
- Cutting and scraping edge
- Suitable on front linkage



Standard Link Box

- Perfect for the smaller tractor
- Strength and reliability helping reduce labour cost
- 3-point linkage as standard
- Manual tipping



MODEL	PRODUCT CODE	HEIGHT (mm)	WIDTH (mm)	VOLUME (Litres)	RAM SIZE (Outside Diameter)
6' Power Link Box	MHB60A	600	1,840	585	70
6'6" Power Link Box	MHB66A	600	1,990	634	100
7' Power Link Box	MHB70A	600	2,145	680	100
5' Standard Link Box	MHSB5A	600	1,535	486	N/A

The above specifications are approximate as our products are under continuous development, so there may be changes and adjustments.

Grass Topper

- Unique blade carrier specially designed from spring steel
- P.T.O. shaft is fitted with shear bolt and double run clutch
- High quality left-left gear box ensures an even cut
- Durable construction designed to last
- Universal 3-point linkage for easy operation
- Suitable for 2 wheel or 4 wheel drive tractors
- Adjustable level of cutting 3” to 7”
- Available in 6’ off-set only



Topper Blades

MODEL	PRODUCT CODE	HEIGHT (mm)	WIDTH (mm)	WEIGHT (kg)
Grass Topper	GCOT6A	1,070	1,900	280

The above specifications are approximate as our products are under continuous development, so there may be changes and adjustments.

Mini Muck Spreader

- All movable parts have grease points to ensure longevity
- Suitable for compact tractors (30 - 50 HP required)
- Operates on 3-point linkage
- Capacity of 1 cubic metre
- Includes P.T.O. shaft
- Low maintenance



MODEL	PRODUCT CODE	HEIGHT (mm)	WIDTH (mm)	WEIGHT (kg)
Mini Muck Spreader	GCMMSA	1,185	950	180

The above specifications are approximate as our products are under continuous development, so there may be changes and adjustments.

Galvanised Yard Scraper

- Heavy duty frame
- Fully galvanised
- Reinforced 25mm fibre based rubber
- Robust spring loaded trip mechanism
- Reversible 450mm deep rubber, which is 25mm thick
- Standard with both category 1 and 2 link-age attachments



MODEL	PRODUCT CODE	HEIGHT (mm)	WIDTH (mm)	WEIGHT (kg)
Galvanised Yard Scraper	MHGYS A	1,060	2,400	175

The above specifications are approximate as our products are under continuous development, so there may be changes and adjustments.

Universal Hoof Tech

- Fully galvanised steel frame for longevity
- Gripped rubber floor for animal grip and comfort
- Moveable side bar for full front hoof access
- Double strap extended hoof block fitted with winch for safe and fast restraint
- Double belly band operated by ratchet winch for secure, controlled lifting and lowering
- Rear rump bar with w-bar for maximum animal restraint
- Suitable to use with a selection of Nugent Head Locking Gates

Optional Extras

- Rear guide gates
- Forklift lifting brackets
- Head Scoop



MODEL	PRODUCT CODE	WEIGHT (kg)	INTERNAL WxH (mm)	OVERALL LxWxH (mm)
Universal Hoof Tech	CHHTCA	350	740 x 1,700	2,400 x 1,185 x 2,100

The above specifications are approximate as our products are under continuous development, so there may be changes and adjustments.

Universal Hoof Tech

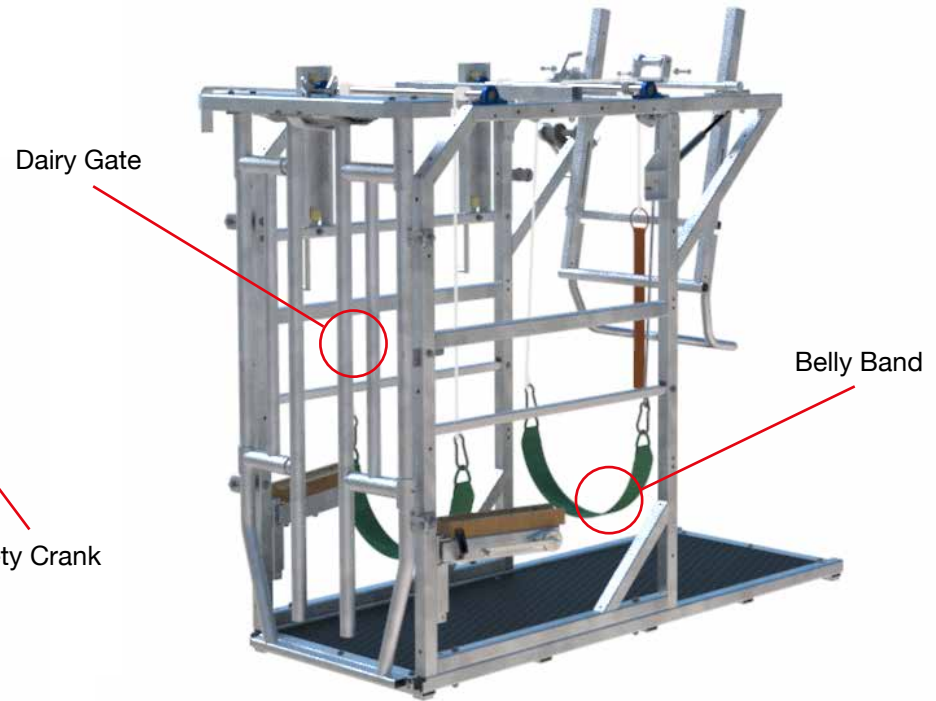
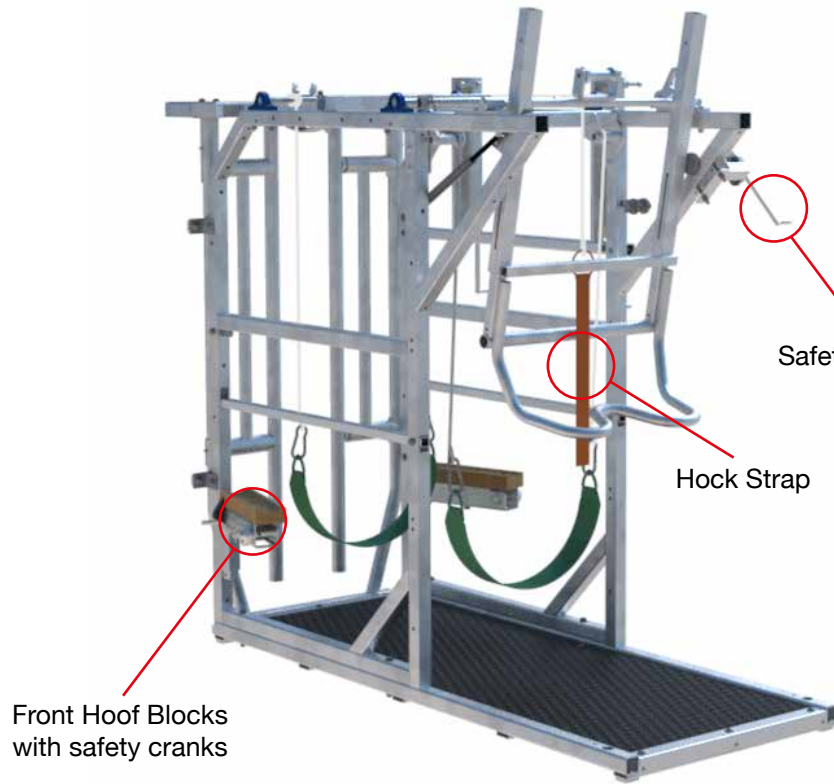

Prime 3000

- Fully galvanised steel frame for longevity
- Gripped rubber floor for animal grip and comfort
- Lockable side gate for full access to animal
- Anti-backing bar for maximum animal restraint
- Left hand side fully accessible for caesarean section
- Safe and easy access to animal neck area
- Suitable to use with all Nugent Head Locking Gates

Optional Extras

- Forklift lifting brackets
- Digital weigh cells
- Rear sliding gate
- Rear hinged gate
- Rear vet access unit
- Head Scoop
- 3-point linkage frame
- Hoof trimming attachment kit



MODEL	PRODUCT CODE	WEIGHT (kg)	INTERNAL WxH (mm)	OVERALL LxWxH (mm)
Prime 3000 + Universal Gate	CHP3CA + CHCGUA	470	740 x 1,850	2,415 x 850 x 2,015
Prime 3000 + Manual Gate	CHP3CA + CHCGMA	600	740 x 1,850	2,730 x 850 x 2,015

The above specifications are approximate as our products are under continuous development, so there may be changes and adjustments.

Prime 3000

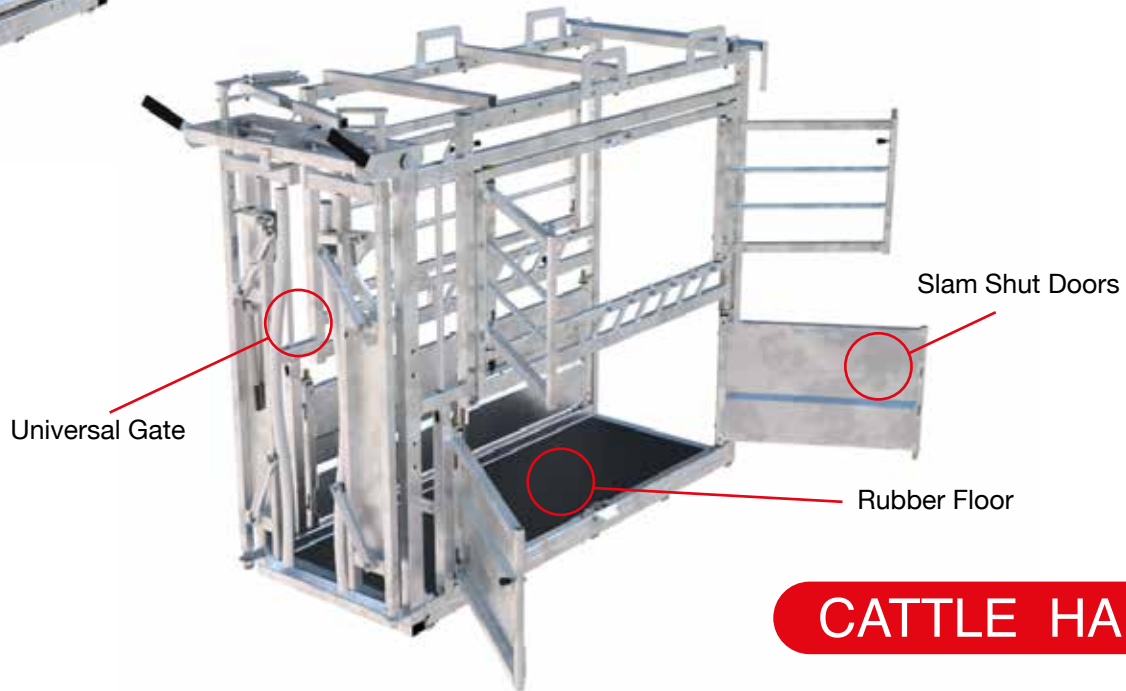
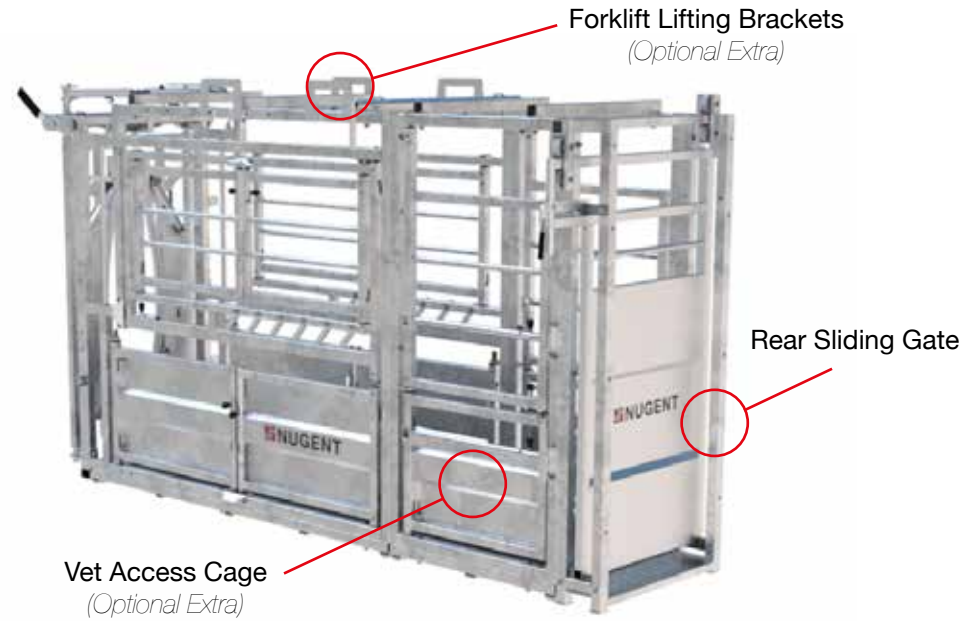

Pro 2000

- Fully galvanised steel frame for longevity
- Integrated floor angles for animal grip and comfort
- Floor designed with reinforced sides to prevent leg lateral movement
- Lower sheeted spring-loaded side gates for easy access to animal feet
- Removable bars for full access to animal
- 3-point linkage
- Suitable to use with all Nugent Head Locking Gates
- Anti-backing bar maximum animal restraint

Optional Extras

- Ratchet rump bar
- Forklift lifting brackets
- Digital weigh cells
- Rear sliding gate
- Rear hinged gate
- Head Scoop
- Hoof trimming attachment kit



MODEL	PRODUCT CODE	WEIGHT (kg)	INTERNAL WxH (mm)	OVERALL LxWxH (mm)
Pro 2000 + Beef Gate	CHP2CA + CHCGBA	393	738 x 1,650	2,395 x 1,000 x 2,000
Pro 2000 + Universal Gate	CHP2CA + CHCGUA	400	738 x 1,650	2,475 x 1,000 x 2,000
Pro 2000 + Manual Gate	CHP2CA + CHCGMA	510	738 x 1,650	2,800 x 1,720 x 2,344

The above specifications are approximate as our products are under continuous development, so there may be changes and adjustments.

Pro 2000

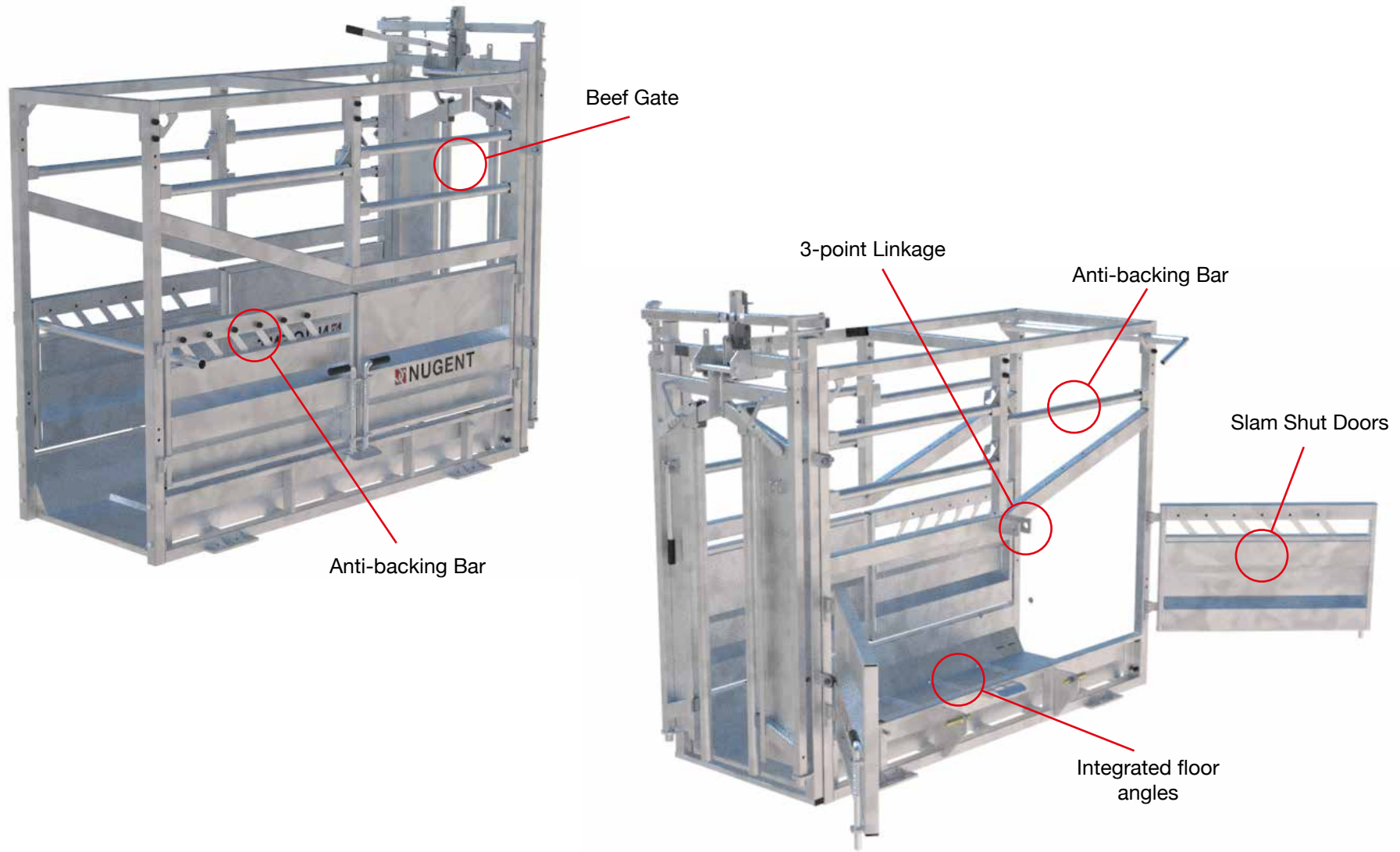

Pure 1000

- Fully galvanised steel frame for longevity
- Steel chequered floor for animal grip and comfort
- Partially sheeted side doors on one side for full access to animal
- Removable central box suitable for caesarean section
- Removable bars for full access to animal
- Suitable to use with all Nugent Head Locking Hates
- 3-point linkage for easy movability with tractor

Optional Extras

- Forklift lifting brackets
- Digital weigh cells
- Rear sliding gate
- Rear hinged gate
- Head Scoop



MODEL	PRODUCT CODE	WEIGHT (kg)	INTERNAL WxH (mm)	OVERALL LxWxH (mm)
Pure 1000 + Dairy Gate	CHP1CA + CHCGDA	350	715 x 2,180	2,300 x 1,000 x 1,836
Pure 1000 + Beef Gate	CHP1CA + CHCGBA	388	715 x 2,180	2,300 x 1,000 x 1,836
Pure 1000 + Universal Gate	CHP1CA + CHCGUA	400	715 x 2,180	2,300 x 1,000 x 1,836

The above specifications are approximate as our products are under continuous development, so there may be changes and adjustments.

Pure 1000

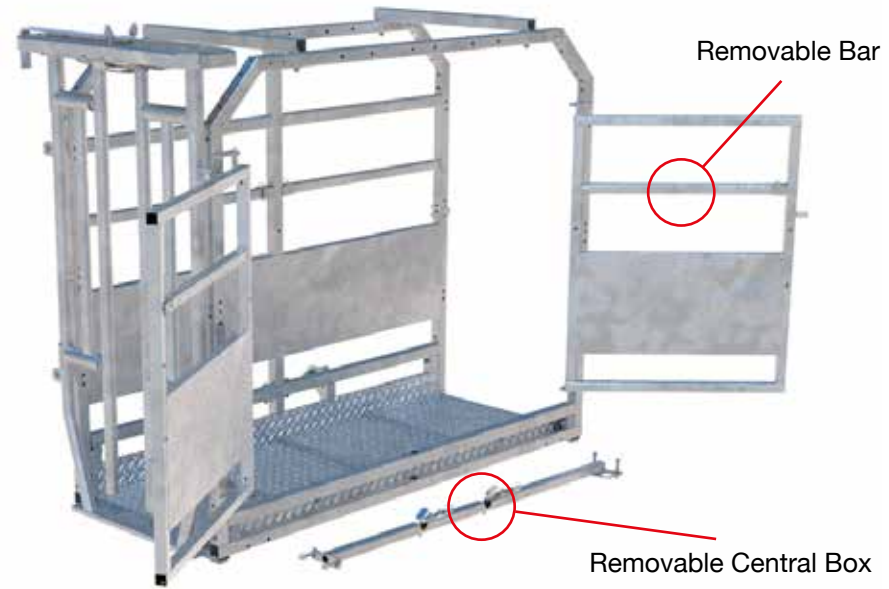
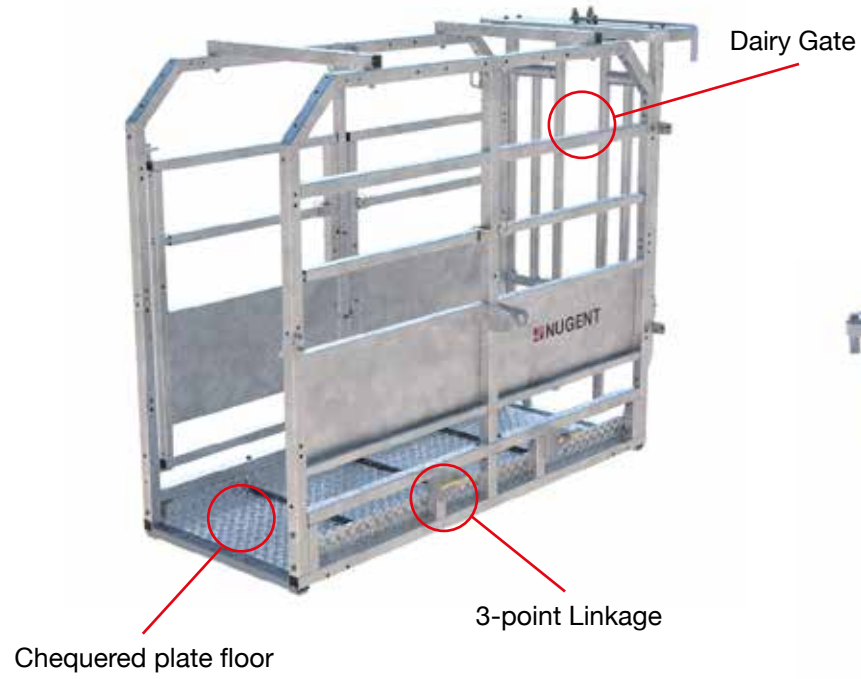

Dairy Head Locking Gate

- Ideal for the smallest of farmers due to its simple operation and competitive price
- Simple one lever operation
- Neck bar adjusts on both sides
- Will stay in the open position
- Gate has been revamped with both height and width increased to suit larger stock
- Fully hot dip galvanised

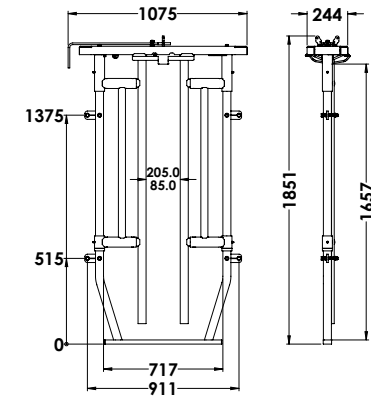

Beef Head Locking Gate

- Fully automatic resetting mechanism
- Heavy duty gate suitable for large livestock
- Spring close reset action
- Designed with sheeted front for strength and durability
- Quick adjustment system allows for fast efficient movement of front bars
- Specially reinforced backing frame allows for easy attachment to any cattle run
- Fully hot dip galvanised

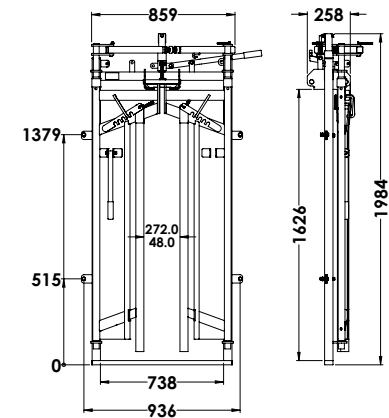

MODEL	PRODUCT CODE	WEIGHT (kg)	INTERNAL WxH (mm)	OVERALL LxWxH (mm)
Dairy Head Locking Gate	CHCGDA	55	717 x 1,657	244 x 1,075 x 1,851
Beef Head Locking Gate	CHCGBA	93	738 x 1,626	258 x 936 x 1,984

The above specifications are approximate as our products are under continuous development, so there may be changes and adjustments.

Universal Head Locking Gate

- When adjusted to full opening, will stay open in position
- When releasing an animal, the lever may be pulled half way resulting in the gate only opening forward, hence preventing the animal backing up the chute
- All quick adjust bars on the Universal Head Locking Gate are spring loaded allowing faster adjustment and more secure holding
- Perfect crush gate to complement any cattle run
- Quick adjust self-closing front gate
- Fully hot dip galvanised

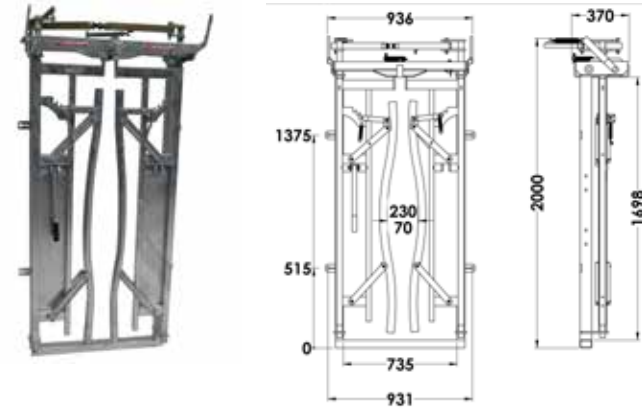

Manual Head Locking Gate

- The simple lever closes the two side neck bars simultaneously in a calm and gentle fashion to safely restrain the animal
- Perfect for lively animals as well as dairy and pedigree livestock
- Front cage provides safety for the operator
- Unique backing frame construction allows for an easy fitting to any cattle run
- Ideal for long horned livestock

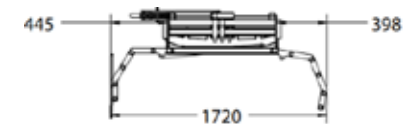
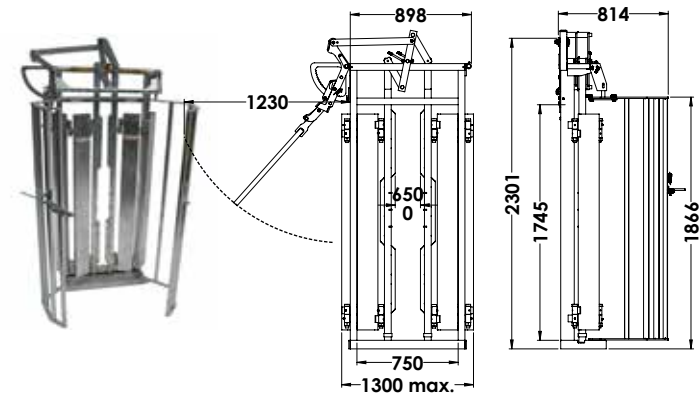

MODEL	PRODUCT CODE	WEIGHT (kg)	INTERNAL WxH (mm)	OVERALL LxWxH (mm)
Universal Head Locking Gate	CHCGUA	105	735 x 1,698	370 x 931 x 2,000
Manual Head Locking Gate	CHCGMA	210	750 x 1,866	814 x 1,300 x 2,301

The above specifications are approximate as our products are under continuous development, so there may be changes and adjustments.

Hoof Trimming Kit

Hoof trimming attachments can all be simply bolted on to the Prime 3000 and Pro 2000 Crushes. The Hoof Trimming Kit comprises of a front belly harness, front belly strap and high level rear leg winch complete with lifting strap and front hoof blocks.



Hoof Trimmer Rear Guide Gates

Foldaway guide gates can be used to guide the animal into the Universal Hoof Tech. The rear gates are only available for the Universal Hoof Tech and are easily removed and detached when required.



MODEL	PRODUCT CODE	WEIGHT (kg)	OVERALL LxWxH (mm)
Hoof Trimming Kit	CHEHTA	40	N/A
Rear Guide Gates	CHEGGA	14	1,885 x 30 x 600

The above specifications are approximate as our products are under continuous development, so there may be changes and adjustments.

Rear Crush Gates

Sliding Rear Gate

Rear Hinged Gate



Vet Access Cage



MODEL	PRODUCT CODE	WEIGHT (kg)	INTERNAL WxH (mm)	OVERALL LxWxH (mm)
Rear Hinged Gate	CHEGHA	25	720 x 1,050	40 x 720 x 1,050
Sliding Rear Gate	CHESGA	63	738 x 1,810	60 x 1,626 x 1,940
Vet Access Cage	CHEVCA	25	920 x 740 x 1,860	920 x 840 x 1,975

The above specifications are approximate as our products are under continuous development, so there may be changes and adjustments.

EXTRAS

Forklift Points

Designed with ease of use in mind these are a simple method of transporting each of the crushes using forklift totes. User can adjust to suit their own forklift width.



Ratchet Rump Bar

The drop down rump bar is friction operated so you only drive the animal forward. If the animal tries to push back the rump bar will not move back up until the operator releases the handle so the operator is always in control.

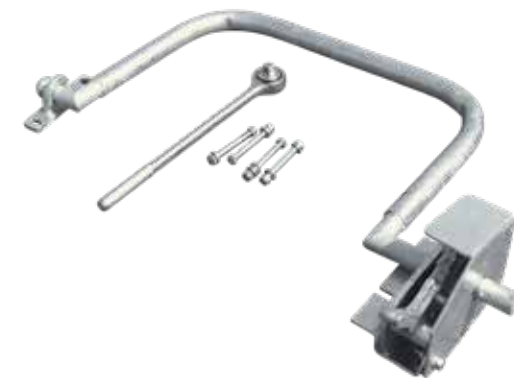

MODEL	PRODUCT CODE	WEIGHT (kg)	OVERALL LxWxH (mm)
Forklift Points	CHEFBA	2	200 x 45 x 100
Ratchet Rump Bar	CHERBA	22	253 x 945 x 650

Head Scoop

The moulded plastic scoop dramatically reduces the available movement of the animal's head, providing greater safety for both animal and operator making it ideal for blousing, drenching, eye treatment, ear tagging and implants. Available in left or right hand configurations, it helps reduce the desire to move backwards and to kick out. The head scoop fits onto all of the Nugent Head Locking Gates using an additional bracket.



3-Point Linkage H Frame

A detachable H frame which can be used to securely transport your Prime 3000 over longer distances. Supplied with rubber bump stops to reduce noise during transportation.

Advised to use with power top link.

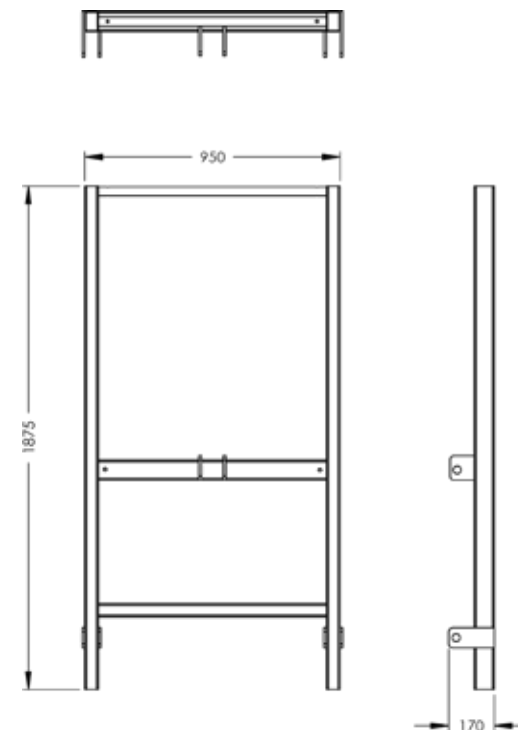

MODEL	PRODUCT CODE	WEIGHT (kg)	OVERALL LxWxH (mm)
Head Scoop	CHEHSA	34	1,530 x 366 x 420
3-Point Linkage H Frame	CHE3LA	45	170 x 950 x 1,875

Digital Weigh System

Together with a Nugent Crush, the Digistar Shear Beam provides today's performance conscious producer with an innovative weighing system that is not only tough, reliable and accurate but also very simple to use. All of the Nugent Crushes can be fitted with a set of Digitstar Shear Beams. The clock operates off standard AA batteries and it's easy read screen is an attractive feature for the operator. The Shear Beams are available in 4000Kg capacity.

MODEL	PRODUCT CODE
Digital Weigh System	CHEWSA



Nugent Trailers

Nugent also manufacture a range of Livestock, Domestic and Commercial trailers. Visit our website to view the full range.



Nugent Livestock



Nugent Flatbed



Nugent Tipper



Nugent Utility



Nugent General Agri



Nugent Quad

EXTRAS

NUGENT



NUGENT ENGINEERING LIMITED

15 Aughnagar Road, Galbally, Dungannon
Co. Tyrone, Northern Ireland, BT70 2PP

T: +44 (0) 28 8775 8583 (Head Office)
+353 (0) 65 671 9111 (Ir/Eire)
+44 (0) 28 8774 0655 (Spare Parts)

E: info@nugentengineering.com
W: www.nugentengineering.com



@NugentTrailers

NUGENT DISTRIBUTOR



© NUGENT 2024. All rights reserved.

Information is accurate at the time of going to print, however, as our products are undergoing constant development, specifications are liable to change. Please check that your product specifications are correct at the time of order.

Do not reproduce this content without prior written consent from Nugent Engineering Ltd.